

30 TON PACKAGE UNIT

SPECIFICATIONS

Trane® Portable Packaged Air Conditioner units contain the best compressor technology available, in order to achieve the highest performance possible. Trane-built scroll compressors are designed specifically to ensure system quality.

These units have high efficiency condenser coils with increased capacity and energy efficiency. This assists with optimizing the required amount of power to operate.

U-shaped airflow allows for improved static capabilities.

The 30 ton package unit is mounted on a skid frame and can be placed on the ground or delivered on a temporary trailer.



30 TON PACKAGE FEATURES

- ◆ R-22 refrigerant
- ◆ Factory installed and commissioned ReliaTel™ controls
- ◆ Phase Monitor
- ◆ Trane 3-D™ Scroll compressors
- ◆ Two-inch standard efficiency filters
- ◆ Sloped condensate drain pan

Call us today! (800)341-4297



GENERAL

◆ Trane® Package Unit Model	
	TCD360A40R1A6EE10BCE00000000PR
◆ CFM (Cubic Feet Per Minute)	12,000
◆ Air Supply	(3) 20" Plenums
◆ Air Return	(3) 20" Plenums
◆ Skid Mounted	-----
◆ Optional Trailer Mounted	-----

DIMENSIONS

◆ Length	17' 8"
◆ Width	8' 8"
◆ Height	7' 6"
◆ Shipping Weight	7,000 LBS

ELECTRICAL DATA

◆ Power Supply	460v/3p/60hz
◆ Connections	Series 16 Cam Type
◆ Minimum Circuit Ampacity	85 amps
◆ Maximum Overcurrent Prot	110 amps

ADDITIONAL INFORMATION

- ◆ Cool Only Unit
- ◆ (16) Air Filters: 16"x20"x2"

30 TON PACKAGE UNIT

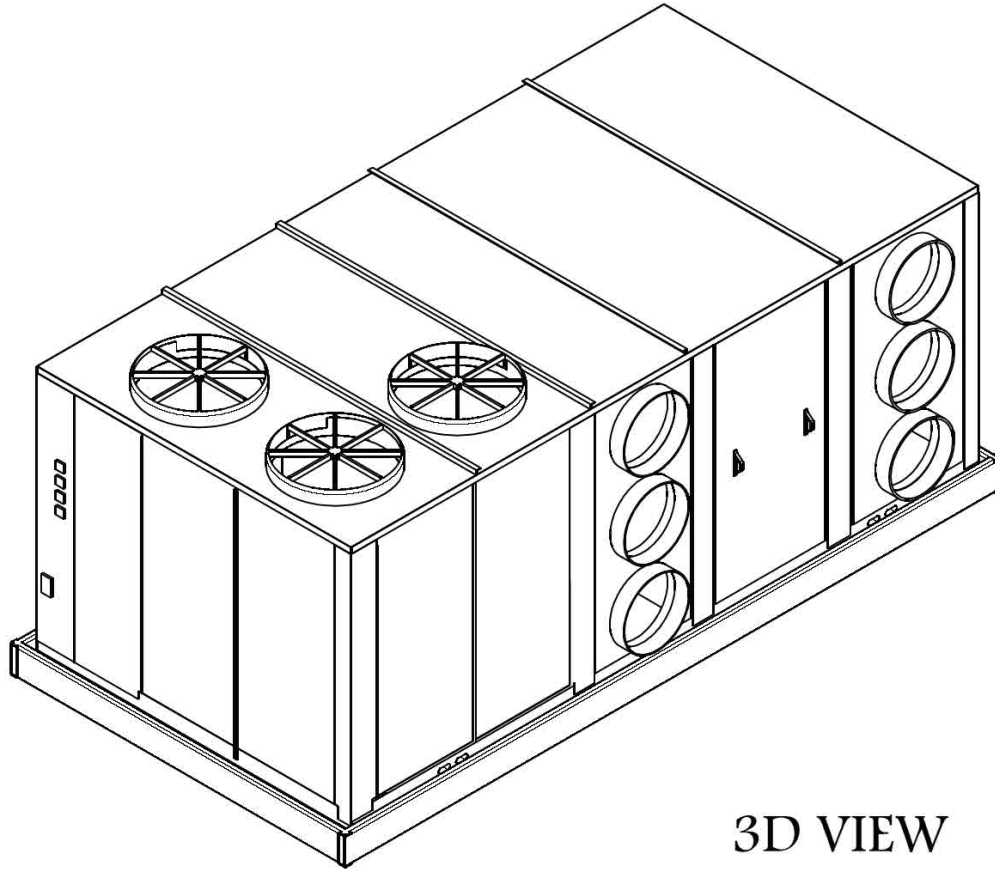

3D VIEW

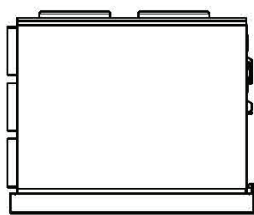

REAR VIEW

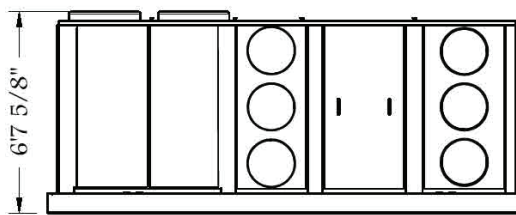

LEFT VIEW

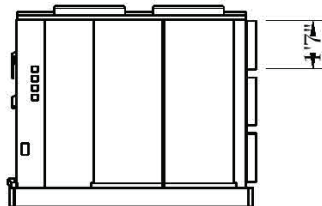

FRONT VIEW

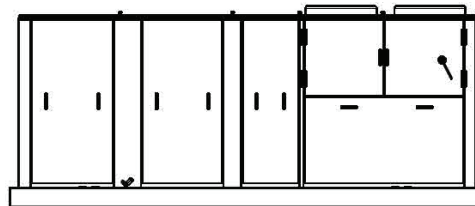

RIGHT VIEW

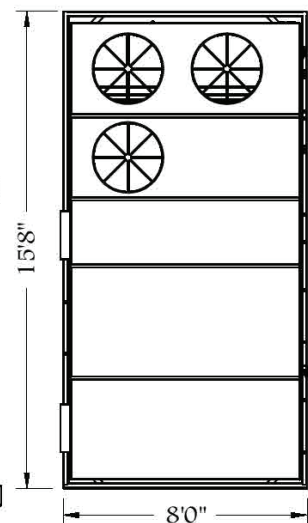

TOP VIEW